

# FlexshadeTetra

Premium Architecturally Designed Shade Structure



Engineered to stand the test of time, the Tetra is a durable alternative to typical shade sails. The design features a conical shaped membrane with four corner columns to allow for its large coverage. The Tetra is available with curved or square perimeter edges and can be linked together or to existing buildings. Popular with swimming pools, sporting clubs and schools, they provide a lifetime of low maintenance.





## Features



### Structural Base Plate

Heavy duty base plate permanently anchored to foundation

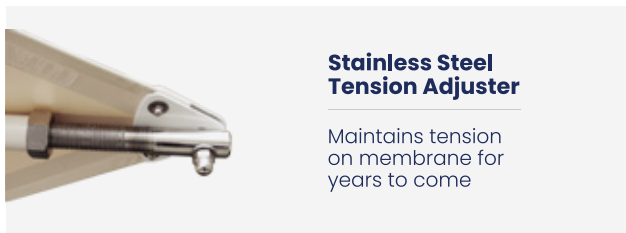

### Stainless Steel Tension Adjuster

Maintains tension on membrane for years to come



### Tetra Twin (Optional)

Dual structures joined together for double the coverage

## Highlights

- > Certified engineered non retractable design
- > Tensioned PVC fully welded membranes
- > Zinc & powder coated steel frames
- > Marine grade stainless cables & fittings
- > Engineered for winds up to 160km/h
- > Fire rated PVC with PVDF top finish



FABRIC WARRANTY



FRAME WARRANTY

## Membrane Colour Options

bright white	dutch green
nature	laguna blue
pearl white	blue
beige	royal blue
brilliant yellow	bright grey
flame red	dust grey
burgundy	charcoal
chocolate	black

Colour swatches are approximate.

## Options

- > Full range of Dulux RAL powdercoat colours for frame
- > Electropolished stainless steel frames
- > Provision for electric lighting and heating units
- > Provision for side curtains and optional corner posts for roll up or zip track fittings.

# Configuration

- 1. Footings  
To suit local conditions
- 2. Point Load  
1kN (225 lbf)
- 3. Apex Cap  
Powder coated aluminium
- 4. Membrane  
Fire rated PVC with PVDF top finish

- 5. Ground Snow Load  
0.95 kPa (20osf)
- 6. Wind Load  
45 m/sec
- 7. Column, Rafters  
Zinc & powder coated

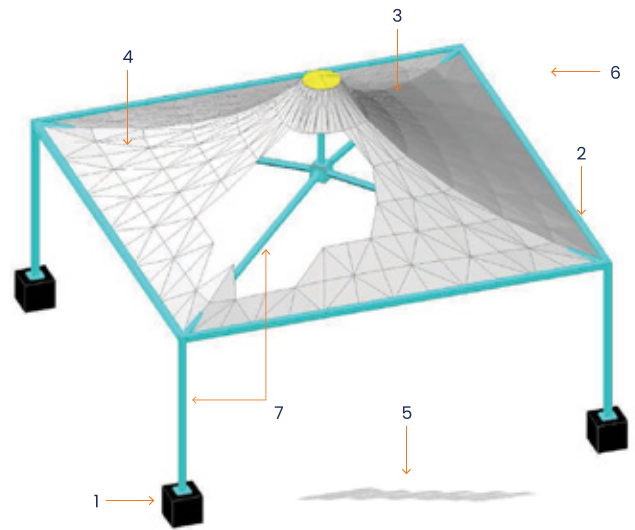

# Dimensions

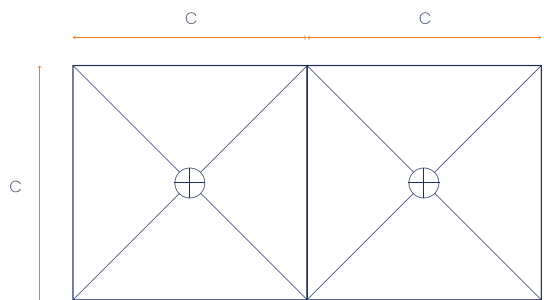
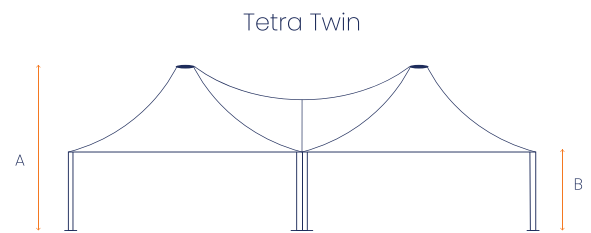
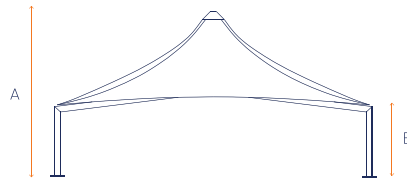
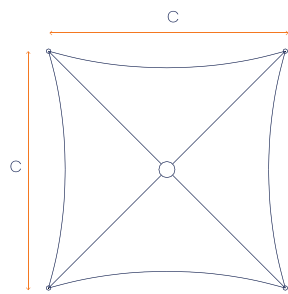

Dimensions (sizes are in mm)			
Type	A	B	C
Tetra 5.0m (Cable Edge)	3994	2400	5000
Tetra 8.8m (Cable Edge)	5175	2500	8815
Tetra 7.0m (Straight Edge)	4500	2500	7000
Tetra 6.0m (Straight Edge)	4400	2500	6000
Tetra 5.0m (Straight Edge)	4000	2500	5000
Tetra 4.0m (Straight Edge)	3765	2500	4000

The Flexshade® Tetra can be designed to suit specific customer requirements for height and plan dimension.

# About the manufacturer

The Flexshade® range of pre-engineered tension membrane structures are part of the Vesl Tension Span Group founded in 1977. These Australian made shade structures are built to unmatched standards and are designed with a fix and forget philosophy.



# Pricing Table

Configuration	Single Price	Twin Price
Tetra 5.0m (Cable Edge)	\$ 16,597	N/A
Tetra 8.8m (Cable Edge)	\$ 31,497	N/A
Tetra 4.0m (Straight Edge)	\$ 13,997	\$ 24,597
Tetra 5.0m (Straight Edge)	\$ 18,397	\$ 32,897
Tetra 6.0m (Straight Edge)	\$ 25,997	\$ 47,097
Tetra 7.0m (Straight Edge)	\$ 33,697	\$ 62,197

Please note that prices may be changed at any time without further notice. For current pricing please visit our website or contact us using the details below.

**Contact  
Project Shade  
Today!**

We are proud to provide Australia with **the best quality** outdoor umbrellas and shade solutions. No matter what the conditions **we've got the shade for you!**

